



# Fact Sheet

Commonwealth of Pennsylvania • Department of Environmental Protection

## Understanding Your Drinking Water Well

### Water Well Basics

A drinking water well uses groundwater as its source of water. Groundwater exists in the spaces, cracks and fractures in the underground soil and rock formations known as an aquifer. An aquifer is the part of the soil and rock that is saturated with water and can yield water to a well. How much water is available depends on the type of soil and rock below Earth's surface. For instance, some rock formations such as limestone can give large quantities of groundwater, while others like shale and diabase (a hard igneous rock) can yield only small amounts of water.

The groundwater table (or water table) is the top of the water-saturated zone. The water table level is usually maintained by rain water that seeps into the ground. As it soaks into the ground, the water flows toward a discharge point – typically a nearby spring or stream. An average of 65 percent of all stream and river water in Pennsylvania comes from groundwater. This is known as “base flow.”

When precipitation decreases and/or water is unable to soak into the ground – from a drought, from paving or when the ground surface freezes in wintertime – then the water table begins to drop. Over time, stream flows begin to decline as groundwater levels are lowered. The water table normally rebounds as winter ends and spring rains soak into the ground. If those rains don't come, the water table and stream levels drop. An increased demand on groundwater in an area, the decrease of precipitation due to a drought and/or a decrease in water recharge areas from paving, can all lower groundwater levels in a region.

### How does a well “go dry?”

A well works by inserting a pump inside a drilled hole to bring water up and into a house through a pipe. If there is no groundwater available to enter the pump, it sucks air instead of water. When the tap is turned on, nothing comes out. In most cases, this is caused by the underground water table dropping below the level of the well pump.

### How much water can my well provide?

When the well is drilled, the water well driller estimates the yield of a well. Wells that are estimated to yield 10 to 20 gallons a minute typically can easily meet all the requirements of a household, although lower yielding wells are generally adequate for most domestic purposes. Wells with lower yields may depend more on

the storage capacity of the well. This is why wells with low yields are often drilled deeper to meet the needs of a home. The deep borehole serves as a “storage tank.”

The water level in a low-yielding well will drop faster than in a well that taps a geologic formation that has a lot of water. For this reason, it's helpful to know what your well's yield is. If you have a low-yielding well (less than 5-10 gallons a minute), you should be very careful of how much demand you place on the well.

The average life of a well is estimated at more than 20 years. However, over time, the yield of a well typically declines for various reasons. At some point, the well may need to be cleaned out or treated to restore its former condition.

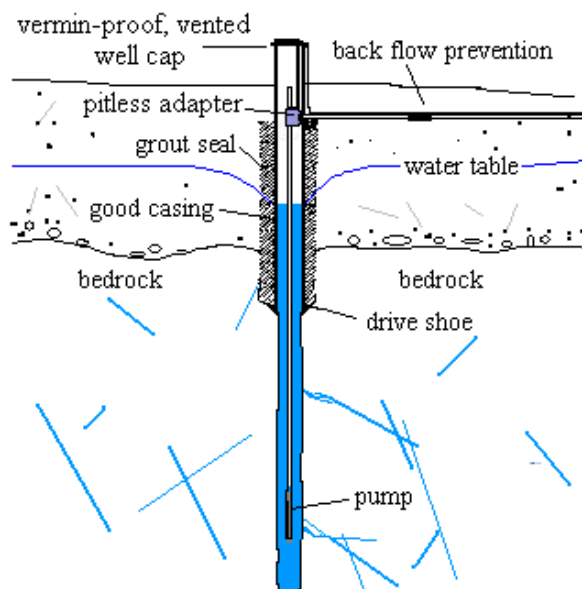

Drinking Water Well

### What can I do to prevent my well from running dry?

Most importantly, practice water conservation. You can find water conservation tips on DEP's website at [www.dep.state.pa.us](http://www.dep.state.pa.us) (Keyword: “DEP drought”). Try to limit the demand on your well by spreading out your daily water-use activities such as bathing, watering the garden and dish and clothes washing as much as possible during the day and the week. If necessary, take laundry to a local Laundromat to conserve your well water supply.

Invest in water-efficient fixtures for faucets and showerheads, turn off water softeners and replace older toilets with newer, low flow models to save on water use. Take the time to repair any dripping faucets and leaking toilets. These seemingly small measures can save thousands of gallons per year in an average household and help to prevent your well from going dry.

### **How can I know that my well is running out of water?**

This can be difficult to determine. Tap water that is muddy or murky in appearance or other changes in water quality can indicate that the well water level is getting low. Air that gets in the line may cause your spigots to cough and sputter as air comes through the line instead of water. Sometimes there will not be a sign until the submersible well pump is pumping air.

However, one certain way to determine if your well is running out of water is to measure the actual water level. This can be very difficult with a deep well, and you may want to call a water well driller. It's helpful to know how deep your well is, what depth the pump has been set, and what the water level is in the well. Knowing the yield of the well can also help you assess the stability of your water supply.

### **How can I find out information about my well?**

When a well is drilled, the driller is required to provide information about the well to the state and to the well owner. If you do not have this information, in some cases the Commonwealth may have a record of the well. Contact the Bureau of Topographic and Geologic Survey at 717-702-2074. If you know the company that drilled your well, you may be able to contact it for a record.

### **I turned my water faucet on but nothing is coming out. What can I do?**

If you're unfamiliar with your well, and you don't know the location where your water comes into your house, you should probably contact a water well driller, or someone who can find the cause of the loss of water. It could be that the electricity is off or a fuse has blown, since pumps and pressure tanks need electricity to work. The pump, pressure tank or the wiring to the pump can also fail. It also could be that the water level in the well has dropped below the pump.

### **Can a new well drilled in my neighborhood cause my well to go dry?**

Possibly. Well owners have a right to a reasonable use of the groundwater beneath their land; however, as neighborhoods and communities expand, private water wells sometimes compete for the groundwater. If you suspect that a neighbor's private well is affecting yours, DEP can provide little help because water wells are essentially unregulated in Pennsylvania. Private water

well conflicts highlight the need for good water planning when land developments are designed.

On a larger scale, if you suspect that your water well is being impacted by a large groundwater withdrawal and you live in central or eastern Pennsylvania, your river basin commission may be able to assist you. Both the Susquehanna and Delaware River Basin Commissions regulate large withdrawals of groundwater in wells used for many agricultural, municipal, industrial and other purposes. In order to withdraw large amounts of groundwater, entities must demonstrate that there is no significant impact on other water resources such as private wells.

### **Can I hire a tanker truck to pour water down my well?**

This should not be done because you will get only as much water as you pour down the borehole. More importantly, you can damage the well's borehole and pump and/or introduce poor quality water from the container or tanker that will contaminate your well.

### **I have run out of water – do I have to drill a new well?**

After making sure that the well is out of water, you can explore several options before drilling a new well. First, can the well's pump be lowered? If you don't have a record of the well's construction details, a water well driller can determine the depth of the well and the pump. If there's room, the pump can be lowered deeper into the borehole. It's also possible that the well could be deepened without drilling a new well. However, for some situations, it may be as expensive to deepen a well as it is to drill a new well. For example, the well casing may have to be pulled out to allow the driller to drill a deeper hole. A driller may not be able to do this for a variety of reasons.

A procedure called hydrofracturing has been successfully used in "tight" rock formations like metamorphic and igneous rocks. Using this method, a driller uses high-pressure pumps to open new fractures in sealed off parts of the borehole. This may be cheaper than drilling a second well, but it can be an involved procedure. You should talk to your drilling firm and ask about its experience with hydrofracturing if your well yield isn't adequate. This technique will not work if the water table has dropped below the pump.

Finally, it may be that a new, deeper well is the only solution. See the DEP guidelines on constructing a new bedrock well at [www.dep.state.pa.us](http://www.dep.state.pa.us) (Keyword: "DEP private wells"). After a new well is installed, the abandoned well should be sealed to protect the aquifer and eliminate any physical hazard. Recommendations for sealing a well are available at the website on private wells.

## How can I find a good well driller?

First, drillers must be licensed in Pennsylvania but that doesn't guarantee good service or practices. DEP recommends using a reputable driller and checking the references that they provide. Also, the National Ground Water Association certifies water well drillers. You can access the list of member drillers in your area at [www.wellowner.org](http://www.wellowner.org) or by calling 800-551-7379. See tips on "Finding a Contractor" at <http://www.wellowner.org/hto-what-is.htm>. Check the yellow pages of your telephone book under "Water Wells" or "Drillers."

## What can I do to make my well water safer?

Proper well construction will help to keep your water supply safe. Other ways include common sense care around the well. See our guidelines for installing wells in bedrock at [www.dep.state.pa.us](http://www.dep.state.pa.us) (Keyword: "DEP Private Wells"). Also, sample your well once a year for coliform bacteria. Consider sampling your water if the physical qualities (taste, odor, color, turbidity, etc.) suddenly change. Proper siting of the well can also help.

## How can I learn more about groundwater and water resources?

- See the DEP web page on private wells at [www.dep.state.pa.us](http://www.dep.state.pa.us) (Keyword: "DEP private wells" and "water resources")
- See the Pennsylvania Geologic Survey's The Geology of Pennsylvania's Groundwater at <http://www.dcnr.state.pa.us/topogeo/groundwater/groundwater.htm>
- Check out EPA's publication EPA *The Water Sourcebooks* at <http://www.epa.gov/safewater/kids/wsb/index.html>
- Download the Water Resources Education Network publication *Groundwater - A Primer for Pennsylvanians* at <http://pa.lwv.org/wren/pubs/primer.html>

- Visit the Department of Conservation and Natural Resources' website at [www.dcnr.state.pa.us/topogeo/](http://www.dcnr.state.pa.us/topogeo/)
- Visit the Susquehanna River Basin Commission's website at [www.srbc.net](http://www.srbc.net) or call 717-238-0423
- Visit the Delaware River Basin Commission's website at [www.drbc.net](http://www.drbc.net) or call 609-883-9500
- Visit the Pennsylvania Groundwater Association's website at [www.pgwa.org](http://www.pgwa.org)

## Water Conservation Tips for Everyone

The average person each day uses about 62 gallons of water, with the majority of water used for clothes washing, toilet flushing and showering, followed by faucet use and leaky fixtures.

Replace an old toilet with a new 1.6 gallon-per-flush model. This measure can save a typical household from 7,900 to 21,700 gallons of water per year;

Save over 1,000 gallons per year by placing a plastic jug of water or commercial "dam" in older toilet tanks to cut down on the amount of water needed for each flush;

Repair dripping faucets and leaking toilets (flapper valves are usually the cause). Repairs can save more than 10 gallons of water per person per day. A faucet dripping at one drop per second wastes 2,700 gallons per year;

Wash clothes and dishes only when you have a full load. When replacing an older machine, consider high efficiency models, which use an average of 30 percent less water and 40-50 percent less energy, saving about 9 gallons per washing machine cycle and 7.5 gallons per dishwasher cycle;

Install low-flow, water-efficient showerheads and faucets and save 1 to 7.5 gallons per minute. Taking a quick shower can save an average of 20 gallons of water; and

Turn off the water when brushing teeth or shaving to save more than 5 gallons per day.

**For more information, call the DEP regional office in your area or contact:**

Department of Environmental Protection  
Bureau of Watershed Management  
P.O. Box 8555  
Harrisburg, PA 17105-8555  
(717) 787-5259

Department of Environmental Protection  
Bureau of Water Supply and Wastewater Management  
P.O. Box 8467  
Harrisburg, PA 17105-8467  
(717) 783-3795

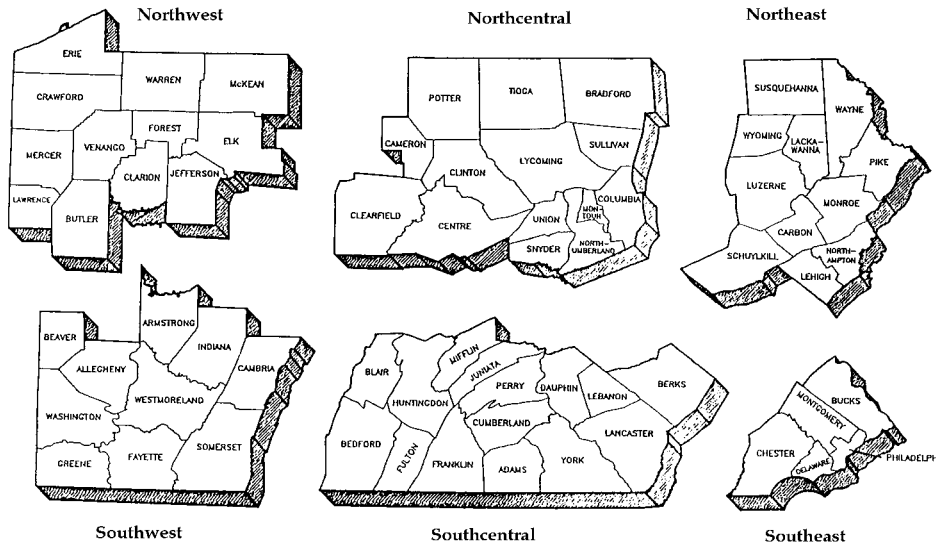

**Southeast Region**

2 E. Main St.  
Norristown, PA 19401  
Main Telephone: 484-250-5900  
24-Hour Emergency: 484-250-5900

**Counties:** Bucks, Chester, Delaware, Montgomery and Philadelphia

**Southwest Region**

400 Waterfront Drive  
Pittsburgh, PA 15222-4745  
Main Telephone: 412-442-4000  
24-Hour Emergency: 412-442-4000

**Counties:** Allegheny, Armstrong, Beaver, Cambria, Fayette, Greene, Indiana, Somerset, Washington and Westmoreland

**Southcentral Region**

909 Elmerton Ave.  
Harrisburg, PA 17110  
Main Telephone: 717-705-4700  
24-Hour Emergency: 1-877-333-1940

**Counties:** Adams, Bedford, Berks, Blair, Cumberland, Dauphin, Franklin, Fulton, Huntingdon, Juniata, Lancaster, Lebanon, Mifflin, Perry and York

**Northwest Region**

230 Chestnut St.  
Meadville, PA 16335-3481  
Main Telephone: 814-332-6945  
24-Hour Emergency: 1-800-373-3398

**Counties:** Butler, Clarion, Crawford, Elk, Erie, Forest, Jefferson, Lawrence, McKean, Mercer, Venango and Warren

**Northeast Region**

2 Public Square  
Wilkes-Barre, PA 18711-0790  
Main Telephone: 570-826-2511  
24-Hour Emergency: 570-826-2511

**Counties:** Carbon, Lackawanna, Lehigh, Luzerne, Monroe, Northampton, Pike, Schuylkill, Susquehanna, Wayne and Wyoming

**Northcentral Region**

208 W. Third St., Suite 101  
Williamsport, PA 17701  
Main Telephone: 570-327-3636  
24-Hour Emergency: 570-327-3636

**Counties:** Bradford, Cameron, Clearfield, Centre, Clinton, Columbia, Lycoming, Montour, Northumberland, Potter, Snyder, Sullivan, Tioga and Union

For more information, please visit DEP's website at [www.dep.state.pa.us](http://www.dep.state.pa.us), Keyword: "DEP Private Wells."